

THE  
**Woodrack**  
October 2007

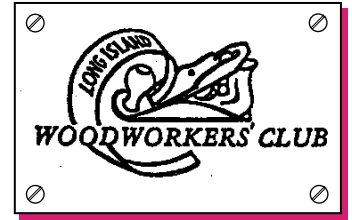

**STEVE MELTZER**  
carving an acanthus leaf

**LIWC BOARD OF DIRECTORS**

<i>President</i>	Mike Daum
<i>Vice President</i>	Bob Urso
<i>Secretary</i>	Gabe Jaen
<i>Treasurer</i>	John Seiple
<i>Trustees</i>	Joe Pascucci
	Jim Macallum
<i>Membership</i>	Joe Bottigliere
<i>Newsletter Editor</i>	Daryl Rosenblatt
<i>Web Site</i>	Harry Hinteman
<i>Show Co-Chairs</i>	Mike Daum
	Bob Urso
<i>Librarian</i>	Steve Blakely
<i>Video Library</i>	Steve Gazes
<i>Raffles</i>	Ed Schnepf
<i>Refreshments</i>	Jean Piotrowski
	Charlie Felsen
<i>Video</i>	Karl Blessing
<i>Photographer</i>	Jim Macallum

**President's Message**

*Mike Daum*



The club will soon be no more. That is to say, we are in the evolutionary process of changing our status as a social group (501C7) to what best describes us now; an educational and charitable organization (501C3). With the help of member Gary Goldberg, we are closer than ever now to reaching this goal in order to qualify for tax exemption. The process will require us to change our name and to amend our current bylaws. A recent vote by the Board of Directors has passed to change our name to "The Long Island Woodworkers". The proposed amended bylaws remain essentially the same, with the exception of the name change and statement of purpose.

**In this issue:**

- President's Message
- Secretary's Notes
- SIG News:
- Cabinetmakers
- LISA
- Turning Guild

**The Saturday Drawing Workshop**  
 Photos of Steve Meltzer

The proposed bylaws is included in this issue of the Woodrack for members to review. A print copy of the proposed bylaws will also be available for review at the Barn during the October meeting. If, at the October general meeting it is determined that the membership has had time to review the proposal, I will hold a vote to ratify the change of name to "The Long Island Woodworkers", and also to amend the proposed bylaws changes so that Gary can proceed with the application process.

Due to the impending dates of our Show on October 27th and 28th, we will not hold a Saturday workshop at the Barn in October. I would much rather know you are in your shop preparing or finishing up your exhibit project for the Show (myself included). We will resume the Saturday workshop on November 10th with a (keeping your) hands-on symposium for tablesaws.

Please keep in mind that the Toy Workshop at the Show is in need of pre-made toys (see plans in this issue), so if your exhibit projects are completed and you have the time, please make up as many as you can (and some extra for Decembers' Toys for Tots meeting). Jim Clancy is handling this effort, so please contact him with any questions. Remember that if you are making toys, use only wooden parts that will not become choking concerns should the toy be dismantled by force (you know the destructive nature of boys).

I am truly looking forward to the Show this year - in the much more manageable venue of the Loyal Order of Moose. The next issue of the Woodrack will be devoted to the highlights of our Show, which the late member Owen Brady so eloquently proclaimed "Our Prom"!

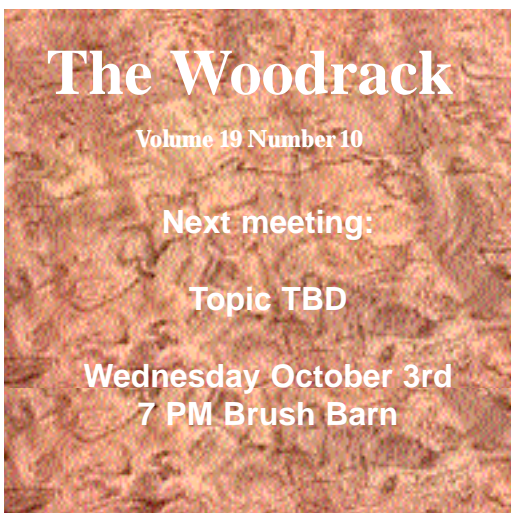

## Show Biz

Mike Daum



This is it! The last written reminder that your exhibit project application forms need to get to me. I expect to receive a few dozen at the October meeting to satisfy the quota we need to fill the exhibit area of the Loyal Order of Moose in Greenlawn. It is important to know that projects must be brought to the venue on Friday October 26th (during the day) for check in, photographing, and placement in the exhibit. If you have transportation difficulties or other issues for that day (or the weekend for that matter), please approach or contact me for a solution. Again, the project can be new or old, previously exhibited, or unfinished. We just want to fill the exhibit!

The Show Committee is busy planning for the weekend of October 27th and 28th and needs your help in spreading the word to the general public! Show tear-off pads with discounted admission will be distributed at the October meeting for you to strategically leave in many places of business - preferably hardware stores, lumber yards, anywhere people who appreciate woodworking and hand-crafted furniture may frequent. We will also be collecting for advance sale tickets, and Steve Costello will take your order at the October meeting. Please make it a point to tally how many friends and family members you will have visiting our Show, and buy your tickets in advance!

Mike Luciano is looking for more volunteers in all areas of the Show. He will be coordinating the various tasks that need to be managed throughout the weekend. Please crowd around him at the October meeting with your offers of support, or contact him asap.

As will be announced at the meeting, we will institute the same admission policy for members as we did at Hofstra. All members will pay \$6 for entry on Saturday, and if you again volunteer to work during the Show on Sunday, you are not required to pay - but you may. If you choose to pay both days, you will be automatically entered in a special members only raffle.

continued on page 4

## Secretary's Report

Gabe Jaen



Mike Daum, president opened the meeting at 7:10 PM reminding the members of the forthcoming trip to Frank Klausz on November 3, 2007. Organizing the trip is Steve Costello taking the first 30 names to sign up. The trip will be a car pool effort.

The wood auction being managed by Melissa Bishop is sorely in need of some help, be it muscle or wood identification. Some of this wood may be at the October show. These are some choice slabs and pieces of wood that you'll regret not getting a piece or two, even if its just to hang up on the wall.

That new sign at the beginning of the Frank Brush Barn driveway was provided and donated by Eddie Piotrowski. Nice job, thanks from the membership.

The Club's Show date and venue has been changed. The new location is the Loyal Order of the Moose located on Pulaski Road in Greenlawn. The Show date is October 27 and 28, 2007. Few vendors signed up for the originally proposed Show which appears to be typical of a good portion of the woodworking shows. The show committee has a concerted effort to assure public awareness. The first order of business, Pads, club web site, posters, etc., are being made for distribution to the public. Newsday will help us with some publicity.

### SIGs:

Cabinets: Robert's Ply was an excellent presentation on the uses of the grades and uses along with world travel in search of it. The September meeting will be on tools for cabinet making.

Turners: the meeting will be on turning birdhouses.

Scrollers: Charlie Felsen won the speed scrolling race and the next meeting will be on Intarsia.

Toy gang: Articles donated to The Morgan center raised

continued on page 4

Show Biz from page three

Steve Costello has offered his workshop in Greenlawn for the building of the "wall" (for hanging exhibits). Someone is needed to coordinate and plan/build the wall project, as Daryl Rosenblatt will be away this year. This will require picking up material, constructing, and transporting the wall to the venue. Jim Macallum has offered to assist with the building. Rich Zimmerman will be available on Friday 10/26 to help erect the wall at the venue. I will be expecting someone to step up to handle this important task!

If you cannot make the October meeting and would like to participate in the Show as a volunteer, I can be reached at 516-528-1426 or email [twwstudio@aol.com](mailto:twwstudio@aol.com).

---

Secretary's Notes from page three

over \$1000.00. Thanks to the ladies from Huntington and their beautiful paintings.

Saturday September 7th workshop: topic will be full scale drawings on suitable media for determining dimensional accuracy directly from the drawing of your intended project.

### SHOW AND TELL:

Charlie James brought in the biggest one yet, a door to his house. The old one had to be replaced, good thing it wasn't his roof. Beautiful job, as always from Charlie.

Robert Coles brought in a table he made not as yet finished where he told the members of a woodworking class he took on storystick techniques and the little tricks he learned on cabinet making. For a moment I thought I was listening to a standup comedian rather than a serious woodworker, but you know if you want to make a serious impression on brain you include humor in your comments. Just think about his comments on the drawer cutout in the apron!

New members: Dave Marshall from Queens who has taken a woodworking course with Marc Adams.

Presenter: Steve Meltzer of Steinway Piano gave a demonstration carving an acanthus leaf pattern. Steve has been carving since he was a kid. I wonder how many trees have his initials on it. He carved the pattern on Mahogany and it cut like butter, all due to his sharpening techniques. The final touch is a polishing with a leather stropping with grinding compound. I've got to ask him to tell me more on this.

The Exotic Wood Group is a local (East Northport) warehouse, catering to turners and cabinmakers. They are, as their name states, not for those who need oak or maple. I ran into Peter Schultheiss and Joe Post at their open house, which was held September 16th. They are not a store, but an internet based business. However, they are interested (they approached me) in holding a members only sale day. They are downstairs, below a dance studio, which has nothing to do with their stock, which is sensational. Shelf after shelf of wonderful exotics. I bought some 4/4 boards of curly bubinga, and one of 6/4 regular bubinga. They have all sorts of turning squares of every type of import, and gorgeous boards of curly cherry. Their stock is a complement to our usual dealers, such as Roberts, J and A and Woodply.

Daryl Rosenblatt

Their contact information is:

Exotic Wood Group

192 Laurel Road

East Northport, NY 11731

(516) 262-8825 but they are internet based (you can't just show up):

<http://exoticwoodgroup.com/>

# AT THE MEETING...



**Charlie James shows off his new door. All hand work, by the way.**

**Robert Coles showing the new table he has been making, at the Connecticut Valley School of Woodworking, where many satisfied members have gone. He said he didn't really care for the table, making him the only one at the meeting with that opinion. He did love the school though.**





**Charlie Felsen wins the speed scrolling competition. However, he refused to explain the cast on his arm after the contest. The steroid tests are pending.**

**Below left, Matt Stern, reporting on the Cabinetmaking SIG; right, Steve Costello with Mike Daum, on the latest charitable endeavors of the 100 Toy Gang.**





**STEVE MELTZER, master carver and foreman of Steinway Piano, and a perennial favorite of Club members, demonstrates his carving of an acanthus leaf. As usual, Steve explains things perfectly, and does some of the most complex maneuvers with simplicity and grace.**





The Saturday Full Scale Drawing Workshop, led by Mike Daum





Upper Wing  
1/4" Wood

Rudder  
1/4" Wood

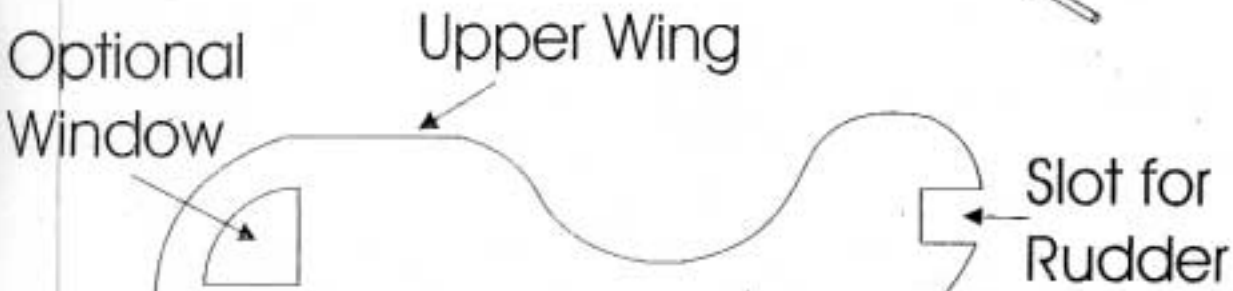
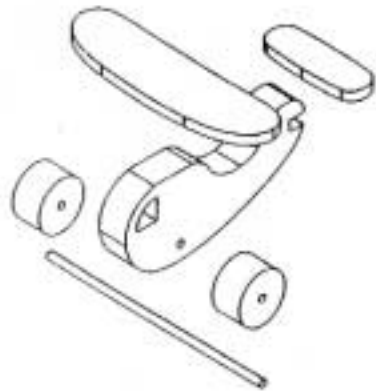

Body  
3/4"

Wheel Position

HOLE SAW  
ABOUT  
1/8" DEEP 15/16

1 3/8  
HOLE SAW  
MAKES WHEEL  
1 1/4 O/S

ROUND ALL  
EDGES.

These two pages are plans for toys needed at the show. Provided by Toy Workshop chairman Jim Clancy, he needs all members to produce as many of these ahead of time as possible. If you have any questions, see him at the October meeting.

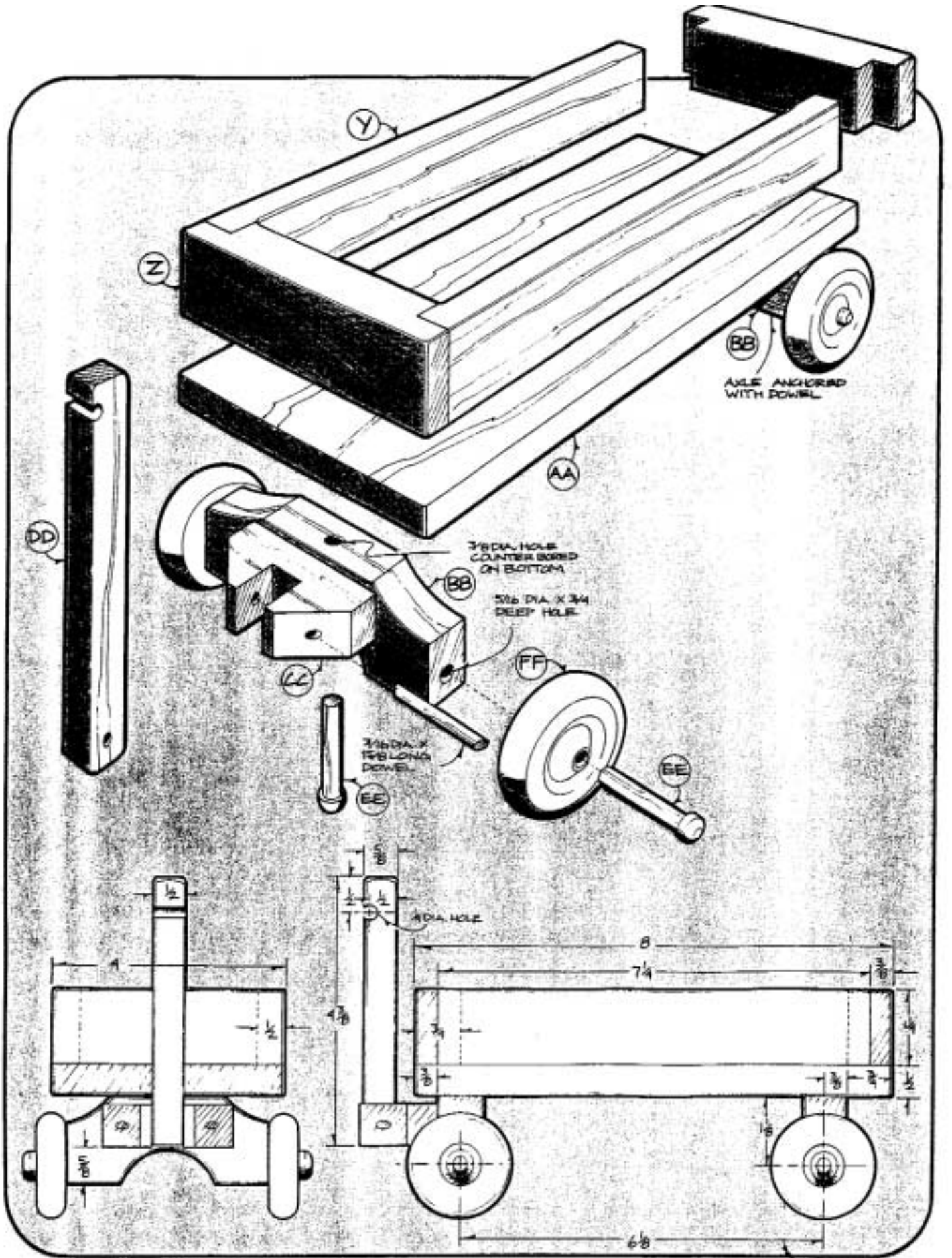

AXLE ANCHORED WITH POWEL

3/8 DIA. HOLE COUNTER BORED ON BOTTOM

5/16 DIA. X 3/4 DEEP HOLE

3/8 DIA. X 1 1/2 LONG POWEL

1/2 DIA. HOLE



**Member Profile: James J. Roman aka Ace**

*Gabe Jaen*

**O**n Tuesday, September 18, 2007 I visited with Ace at his place of business, the Geezer Shop. At least that's what the sign on the door read. If you happen to be in the back parking lot of Sears located on Jericho Turnpike in Commack, you're about 200 feet from his shop. His business card reads Custom Woodworking but there's more to it than that.

Born in Bayside Queens and raised in the Babylon area where he graduated from Babylon High school, Ace put some time in the U. S Army during the Vietnam period as a sergeant repairing fixed wing airplanes, which gave him the natural direction to become a machinist in the aerospace industry. One particular company was Airborne Instrument Laboratories known as AIL. As it turns out we have a mutual friend though we worked there at different times. There he worked with toolmakers and gained a vast amount of knowledge, but intuitively felt that this may not provide the kind of growth he wanted. So, on a part time basis he enrolled in design and drafting courses at Farmingdale Technical College and spent the next few years working behind a drafting table rather than a lathe or milling machine. Eventually that table became a computer and the paper a screen, and Computer Assisted Drafting was his new challenge.

Ace is married and has a cat, and this is his second woodworking shop. He had a partner in the first but in this present shop it's all his. He's been here 2 years and enjoys the laid back atmosphere that exists. There is no pressure, no deadlines to meet, just come to work around 10:00 AM and work till 6:00 PM. No employees to watch over - just 3 associates that exchange expertise in their own respective shops. One is a shop around the corner from him that does antique and furniture repair that feeds him work, the other is an upholsterer and the third is a finisher. Typically there is one job he has now, it's a chair, in the shape of a women's high heel shoe. He is making some chair frames, as you can see in the picture, which will go out for upholstering and finishing. There is a little girl's version and one for a boy. Most of the frame is bandsawed and sanded with the aid of templates.

The shop is more than ample in size and is well equipped with all the usual power tools and hand tools you expect to see. In addition, he has a small machine shop at home to augment his needs to get things done in the shop - like designing special cutting tools for his woodturning lathe. I saw different jobs in process, some wood turned parts, extensions being made for an Oak table, the chairs. But there are other things on his mind for potential products (which I won't disclose) that look promising.

Ace joined the Club about a year ago and he had some nice things to say about the club, mostly that the club provides the members with what they are primarily interested in, woodworking. But he also says the camaraderie is also there. So much so that he is interested in trying his hand as a mentor. You know, spend some time with him in his shop - a day, a couple of hours - as he shares some experience with you. Sounds like a nice deal for someone.

Easy to talk to, eager to show his skills and past work. It was again a pleasure to visit with a member; you learn, you grow. When are we going to get together?





*The Long Island Woodworkers By-Laws*

Proposed Revision: September 22, 2007

**Article One: Purpose**

The Long Island Woodworkers (LIW) advances the arts and crafts of fine woodworking through education, programs, and activities focused on sharing the knowledge, skill, and experience of woodworkers and the utilization of such knowledge, skill, and experience to provide educational and community services.

**Article Two: Membership**

Membership shall be available to any person with an interest in woodworking. A prospective member shall complete an application form furnished by the Membership Chairperson. Upon payment of the prescribed dues, he or she shall become a member, receive a membership card, and be placed on the membership roster and mailing list of the LIW. Members in good standing may vote, hold office, serve on committees, and participate in exhibits and other LIW activities.

Persons under the age of 18 years who are not a member of the LIW must be accompanied by a parent or guardian at all times during a LIW monthly meeting or workshop. To become a member, the minor and his/her parent or guardian must meet with the Membership Chairman at a monthly meeting in order to sign a membership consent form. The parent or guardian will be advised that their child's participation in some activities of the LIW may be restricted due to safety concerns, as determined by the Executive Board of Directors. Once membership has been granted to a person under 18 years of age, the parent or guardian must assume total responsibility for monitoring their child during the meeting, and provide a means of transportation at the end of all LIW meetings.

To meet the necessary and proper expenses of the LIW, an annual membership fee shall be collected from each member with the amount of the fee to be set by the Board of Directors. The membership fee covers the LIW year, which runs from January to December. For new members, applications received after September 30<sup>th</sup> will apply for the remainder of the year and apply to the following full year.

**Article Three: Board of Directors**

The LIW shall elect through the general membership vote a President, Vice-President, Secretary, Treasurer, two Trustees, Membership Chairperson. These collective positions shall be called the Executive Board of Directors. The Chairpersons of the following standing committees shall be nominated by the Executive Board and ratified by the general membership with a vote at a general meeting: Show Chair, Newsletter Chair, and Website Chair. These collective positions shall have the right to vote at a Board meeting. The Past President may remain a voting Board member ex-official for one year.

The Board of Directors shall have the right to establish committees deemed necessary for the running of the LIW. The Board of Directors shall also determine which of the committees shall be represented by a member or a full officer of the Board. If an officer of the Board holds more than one voting position, that person's vote will only count for one.

A quorum of two-thirds members of the Board must be present at a Board of Directors meeting when matters of LIW policy, welfare, and finance are to be voted upon.

Should a vote be necessary at any meeting of the Board of Directors attended by an even number of Directors and if, and only if, a tie-vote should result, the President, or in his absence the Vice-President, shall be required to cast a second vote as a tie-breaker.

The Board of Directors shall meet at least twice yearly or as the President deems necessary in order to conduct LIW business.

**Article Four: Office Vacancy**

If there is a death, resignation from office, or resignation from the LIW of any of its officers or Board members, the remaining Board shall, with at least a quorum present, and as soon as is practical, name a successor to carry out the unexpired term of office. If no successor is to be named, a reason shall be explained to the membership, preferably via the newsletter.

**Article Five: LIW Meetings**

LIW meetings shall be held once each month of the year at times and locations set by the Board of Directors. The Board may amend the schedule for extraordinary reasons.

**Article Six: Committees**

Committees shall administer routine activities of the LIW. The following standing committees shall be maintained in relation to their respective duties:

***Program Committee***

The Program Committee's responsibilities include but are not necessarily restricted to the following: to schedule specific programs and workshops to meet the needs of the members. The Program Committee will also be responsible for keeping safe and maintaining LIW audio-visual equipment, and monthly meeting raffles and refreshment arrangements. A yearly budget will be set by the Board of Directors based on the request of the Program Committee Chairperson, and will be reviewed annually. The Board of Directors will establish the maximum amount that can be spent for any one LIW meeting or special event. The Vice-President is the Program Committee Chairperson.

***Show Committee***

The Show Committee will schedule and operate an annual showcase of member's works, and will operate with a budget generated by the proceeds of previous shows. If the show is discontinued, the monies in the show budget will be remanded to the LIW treasury. The Board of Directors will review the show budget annually. If the position of Show Chair is vacated after the dates of the last show, the Show Committee will nominate a Show Chairperson and present it to the Board of Directors. The Board will vote for approval of the nominee and ratify the vote with the general membership at the next monthly meeting.

***Newsletter Committee***

The Newsletter Committee's duties will include but not be limited to preparing and distributing a monthly newsletter to all members in good standing, and maintaining an annual budget authorized by the Board of Directors.

***Website Committee***

The Website Committee shall maintain and update the website URL [www.liwoodworkers.org](http://www.liwoodworkers.org) with current and pertinent LIW information. This will include establishing member access as determined by the current roster. The budget of the Website Committee will be reviewed annually and determined by the Board of Directors.

***Library Committee***

The Library Committee's responsibilities will be to safeguard and distribute LIW books, tapes, and DVD's at the monthly LIW meetings and to update the existing database as necessary. The Committee will also provide updated information to the Website Committee as necessary for listing items online. The budget of the Library Committee will be reviewed and determined by the Board of Directors.

**Article Seven: Nominations and Elections**

A Nominating Committee shall be assembled by the presiding officer at the September LIW meeting

whose purpose is to create a list of candidates for office elections. The proposed slate for the Board of Directors shall be published in the LIW's newsletter prior to the elections.

Elections shall be held annually at the November meeting. The Nominating Committee will present the proposed slate and additional nominations will be received from the floor. To be elected to office, a candidate must be a member for at least one year and have a majority of the vote of LIW members present. A tie vote must be redone at the same meeting or scheduled to be held again at the next meeting.

The term of office for President, Vice-President, Secretary, Treasurer, Trustees, and Membership Chairperson shall be for one year. Officers may be re-elected to consecutive terms. The chairpersons of the standing committees shall also be elected annually. All elected positions shall run from January 1<sup>st</sup> to December 31<sup>st</sup> with the exception of Show Chair (see article 6).

### **Article Eight: Board Meetings**

Meetings of the Board of Directors shall be open to any member of the LIW who shall have the right to state his views on any subject under discussion. Any LIW member may suggest a subject for Board discussion at a meeting. Any LIW member may take part in the discussions of the Board but may not cast a vote at Board meetings. Notice of a scheduled Board meeting will be announced at the previous LIW meeting or printed in the newsletter for members' awareness, except in cases of emergency or extreme circumstance. Any changes to these by-laws are to be published in the newsletter.

### **Article Nine: Amendments to By-Laws**

Proposed amendments to the by-laws by a LIW member shall be presented to the Executive Board in writing and shall contain the signatures of no less than ten (10) active members (in good standing) outside of the Board of Directors. The exception would be an amendment proposed by the President or a member of the Executive Board. If approved by the Executive Board, notice of the proposed amendments shall be published in the newsletter. Print copies of the proposed amendments shall be made available to the general membership, and shall be voted on by the members at the next regularly scheduled meeting. A two-thirds (2/3) approval vote of the assembled members shall be required to amend the by-laws.

### **Article Ten: Records and Financial Audits**

The officers of the LIW shall keep appropriate records of the LIW's business, including membership lists, minutes of the meetings, financial records, records of LIW assets, lists of past and scheduled speakers, and so on. The outgoing officers shall deliver those records to their successors prior to the first meeting of their new terms of office.

It shall be the duty of the Board of Directors to perform an audit of the accounts of the treasurer of the LIW whenever they consider it appropriate, but not less than once a year if regular reports are not issued giving adequate disclosure that satisfies the Board and its members.

### **Article Eleven: Reports**

At the option of the presiding officer at each meeting, the reading of the minutes and the making of a President's and/or Treasurer's report may be waived except that at least once a year formal reports by these two officers shall be given to the membership of the LIW either in an open meeting or in writing.

### **Article Twelve: Buying and Selling**

Conducting buying or selling activities during either formal or informal meetings shall be limited to items or services relating to woodworking that are made equally available to the entire membership present unless the Board of Directors has considered the situation and granted an exception.

### **Article Thirteen: Grants and Awards**

The LIW may, as it chooses and as its resources permit, bestow scholarships, awards, and grants in aid or

## The Marketplace

other forms of help or recognition on persons or organizations pursuing courses of study, doing scholarly research, or who are engaged or have been engaged in projects which are in keeping with the stated aims of the LIW.

### **Article Fourteen: LIW Representation**

Members in good standing may use the LIW logo on stationary (business cards, letters, and forms) only if identifying themselves clearly with the word “member” printed in close proximity to the LIW logo, unless they are a current officer of the LIW, in which they may identify themselves in their current position in office. Clothing and items purchased and worn with the LIW logo shall be only for promotional consideration of the LIW, and not necessarily represent a LIW member or a person acting in an official capacity on behalf of the Long Island Woodworkers.

**The annual Smithtown Heritage Fair was held Sunday September 16th. Lacking this year was Bob and Rich's prize pig, but the LIWC was there in full force. Also present was Bob Urso. Photos by Jim Macallum.**







## LISA Minutes

*Rolf Beuttenmuller*

**W**e had a small turnout for the July 19th meeting; it seems that we all have too many other commitments during the summer months. The collaborative clock project is almost assembled. (not an easy task) and will be presented for show and tell at the clubs main meeting show and tell when complete.

Our project for this meeting had been making scrolled candlesticks. We only made a couple of them and some of the cutting problems were discussed and hopefully cleared up. Future meetings were discussed, in particular we talked about what our members would like to see presented.

It is always difficult to provide projects that keep our senior skilled scrollers interested without scaring our new scrollers away. One of the suggestions was to do a session on cutting techniques, especially inside and outside sharp corners. A refresher in these areas is always welcome.

We had several items, Gabe brought in a beautiful cherry trinket box that he scrolled. Barbara, Matt and Tim also brought in several items. Barbara and Tim cut their pieces from veneer (extremely delicate)

August, 16, 2007 – Idea Exchange and scroll saw speed race. The laid back meeting for an extensive Show and Tell and a question and answer session

September 20, 2007 – Intarsia. We will probably use a Cathy Wise kit.

October 18, 2007 – Toys-for-Tots. We will do cutting for the 100 Toy Gang. Bring Saws.

November 15, 2007 – Holiday decorations. Bring Saws.

December 20, 2007 – Picture frames. A discussion of how to make picture frames, different design ideas, finishing, types of wood, using hinges.

## SHOW AND TELL





# LISA IMAGES





## Long Island Cabinetmakers

*Steve Blakely*

The meeting of the Long Island Cabinetmakers (LIC) was held on Tuesday, September 11. President Matt Stern, who was giving a presentation on “Power Tools for Cabinetmaking” asked Steve Blakely to chair the meeting. Vice President Joe Benlevi was not available.

At 705 Steve B. welcomed those in attendance and began the meeting. He first mentioned that he hoped all the attendees remembered 9/11/01 in their own way. He further went on to talk about the LIC mission; that those who have not purchased raffle tickets still have the chance to do so, and that coffee was available in the back of the room. Gary Goldberg reported that the LIC has 35 paid members and also reported on our finances, which included that the membership dues will cover the cost of the rental of the building and there will be no need for assistance funding from the Long Island Woodworkers Club (LIWC). Gary also requested that IF POSSIBLE, all transactions to the LIC be completed in cash. This was to relieve the LIWC treasurer of the responsibility of cashing checks for the LIC. Steve mentioned that the LIC board met and came up with an exciting agenda for the next few meetings. He mentioned that the Vice President, Joe Benlevi would be putting the agenda on the LIWC website soon if it is already not there.

Rich Z. talked about the 12” Amana Blade that Steve C. had shown at the LIWC meeting with the broken teeth. He said that he and Steve went to American Saw on Route 112 in Medford and was told that they could do nothing about the blade. Rich and Steve C. then decided to go (decked out in their LIEC log shirts and pictures of the projects they have made for various organizations) to the Amana Distribution Center in Farmingdale. There they were introduced to a technician who told them that they in fact broke the blade, but there was a good explanation for it. The technician explained to Rich and Steve C. that someone probably used the blade before the machine got up to the full speed. He has seen this happen before and suggested that whenever using any shop saw that the user ALWAYS allows the machine

to attain full speed before cutting any item. (A VALUABLE LESSON FOR US ALL !!!) The technician then went into the back (of the building) and came out with a brand new blade for Steve C. and wished them luck. Nice work Rich, Steve and thank you AMANA DISTRIBUTION CENTER!

Steve B. then introduced Matt Stern for his presentation on “Power Tools for Cabinetmaking”. Matt began the presentation and discussed dimensioning lumber, joinery and power tools vs. hand tools. He reviewed the pros and cons of table, circular, band, miter and radial arm saws. Foremost on his list was safety and he discussed the possible safety hazards of each. He also spoke about how to make the safest cuts on each saw. He then discussed jointing for straightness using a jointer, router, drum and regular sander and thickness planer. Additional points of interest from both Matt and the audience was: When jointing wood, go with the grain – mark the side which has been jointed; a thickness planer is probably more accurate; relieving tension on a band saw; what actually makes a dual compound miter saw – it swings both ways! (you had to be there); to stop chip out, make a light cut on top of the wood by pulling the handle of a sliding miter saw to you and then push down and back on the miter saw to complete the cut and on a table saw, make a light cut on the face then flip over the wood and make the complete cut; check for nails or staples before cutting so as not to ruin the blade or cause kickback; and always use a metal brush on the sides of wood to eliminate any gravel or other debris that might have become imbedded in the wood while it was standing up (somewhere else, obviously not in YOUR shop.) It was also suggested that there be a presentation on truing your table saw, but Steve B. pointed out that this was one of the agenda topics for a Mike D. run Saturday workshop. Mike said this subject would be addressed in the October workshop, being held the Saturday after the general LIWC meeting.

With it being a few minutes after 9 PM, it was decided that Matt would be invited back at a future date to finish his well-prepared presentation. Thanks so much for the hard work Matt!



# Turning Guild Photos



# The Marketplace

4/4 Spalted Beech lumber for sale. Most 9" and wider 8' long, with great figure. [http://www.righteouswoods.net/Beech\\_European\\_Spalted.html](http://www.righteouswoods.net/Beech_European_Spalted.html) is selling it for \$14.20 a board foot, I am asking \$7 a bf for quantities less than 50 bf, \$5.50 for quantities over.

Powermatic 719A Hollow Chisel Mortiser with 4 chisels and mobile base. Great condition, works like a champ. Asking \$595, about \$950 for all this new, save money and get a great tool.

**Bill at [wmarr@optonline.net](mailto:wmarr@optonline.net), or 631 312 6617**

Performax 25 x 2 Dual Drum Sander with Power Feed; 5 hp 220 V Leeson Motor. Machine has "low mileage"

**Bob Urso (631) 724-4625 or through the club website**

12" Sear's bandsaw, good condition, \$175, 14" Reliance Bandsaw, good condition \$225, 10" Ryobi Tablesaw, good condition

**Charlie Morehouse (631) 271-7251**

3 hp 4 bag Reliant dust collector \$275, 12" radial arm saw, rusted but runs. Free to a good home.

**Willie (631) 235-0186**

Laser etched photos on wood.

**Contact Dave Schichtel at (516) 671-5964 or [www.the-wood-shop.com](http://www.the-wood-shop.com)**

Foley Model 387 Automatic Saw Filer  
Complete with extra files.

**Norman Picht (631) 242-9255**

Routers, Sanders, Drills and more for sale,

**Dennis Taddeo 631 543 2256**

Shopcraft Variable Speed Wood Lathe Model T 6750 700-1800 RPM 110V Capacity 7" x 32" with four tool rests: 6, 7, 8 & 12" 1 spur drive center, instruction and maint.

Manual; 6" face plate heavy duty, steel with 1" dia. Centering pin brass; 1/2" = 20 spindle with 3/4-16 adapter. \$85

**James J. Roman (631) 271-7296**

Fine Woodworking Magazines, issues 1-159 plus index to 120 Excellent condition \$475

Woodsmith Magazines, issues 1-143 plus index to 126 Excellent Condition \$300

**Gene Kelly (631) 265-5218**

L.I. School of Classical Woodcarving & Woodworking Schedule for 2007 visit; <http://homepage.mac.com/walterc530/>

Need someone to tune a working Craftsman 10" radial arm saw for a fee

**Harold Schechtel 631-539-6290**

I have a live black walnut tree which is 55 inches in circumference at one ft. above the ground and extends to 25 ft. to the first branch. The tree is yours for the cutting.

**Jim Ganci at 631-271-7517 in Dix Hills**