

Shaker Classic

Change the legs to change the look

2 Ways



**BY CHRISTIAN
BECKSVOORT**



Not long ago, a couple ordered a set of cherry side tables from me, one for each side of their pencil-post bed. I based the design on a Shaker side table from Canterbury, N.H., although virtually every other Shaker community had similar designs. As a surprise (I don't recommend this unless you are very familiar with

your clients), I decided to make slightly different versions: one with square tapered legs, the other with turned tapered legs.

The overall design is a basic, timeless one that can move from bedroom to living room. But notice how the simple leg change alters the whole feel of the table. Tweaking the dimensions or

shapes can make a big difference in the look of a piece of furniture. As far as difficulty goes, the table with tapered legs is a very good project to tackle if you're a beginner, and the one with turned legs adds a bit of a challenge. The rest of the construction is standard mortise-and-tenon joinery, a dovetailed top rail, and a dovetailed drawer. I start with the legs, move on to the joinery, add the drawer, and finish.

Tackle the joinery: mortises, tenons, and a dovetail

Once the legs are finished (see "2 options for legs," p. 32), the construction is the same for both tables. The first step is to add

Side table with drawer

This little table design, taken from the Enfield, N.H., Shakers, is rock solid, no matter which legs it stands on.

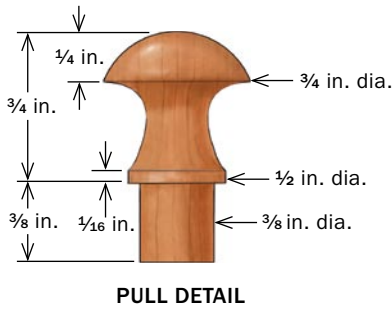
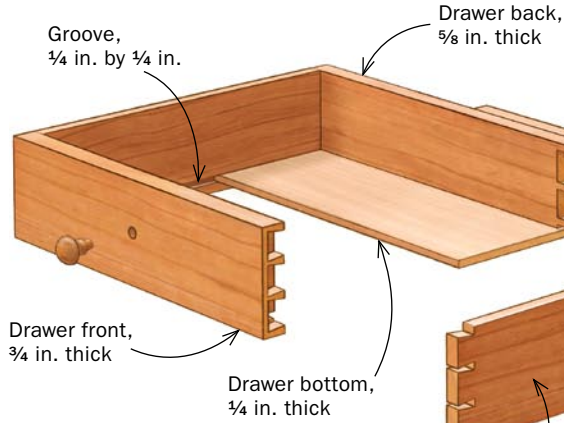
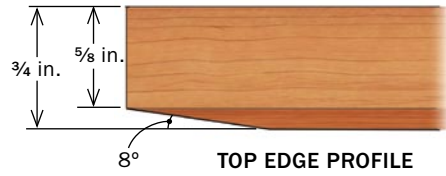

To purchase digital plans and a complete cutlist for these tables and other projects, go to FineWoodworking.com/PlanStore.

TAPERED LEG
A simple shopmade jig on p. 32 makes quick work of the tapered leg design.

TURNUED LEG
Learn how to make a classic turned leg with three simple lathe tools, p. 33.

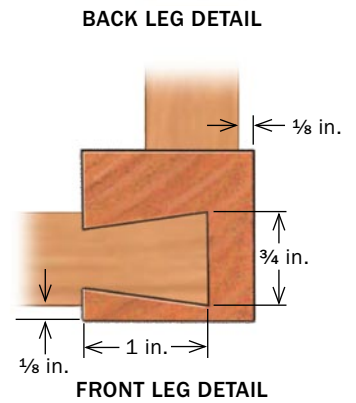
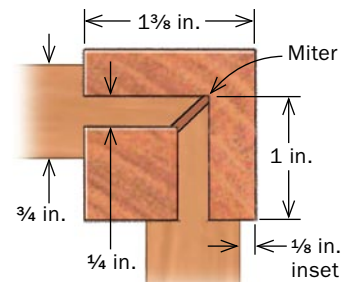
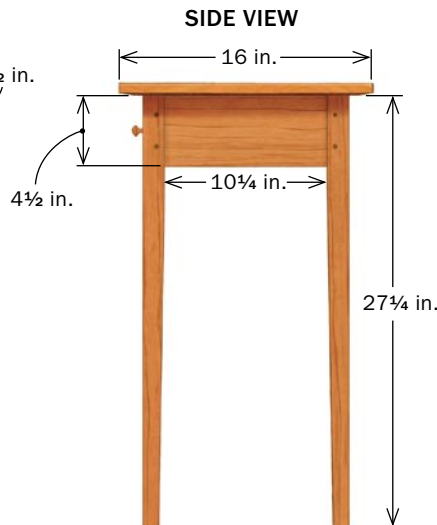
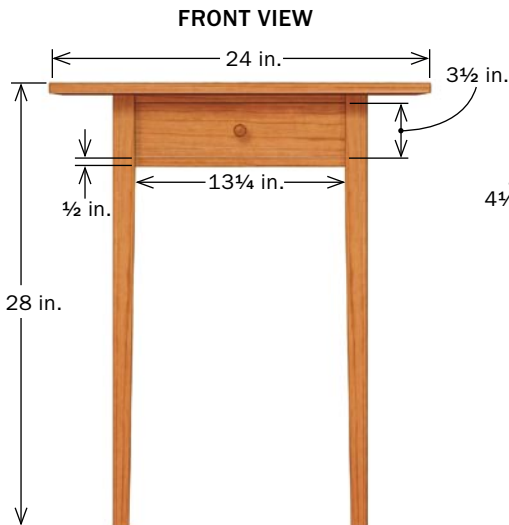
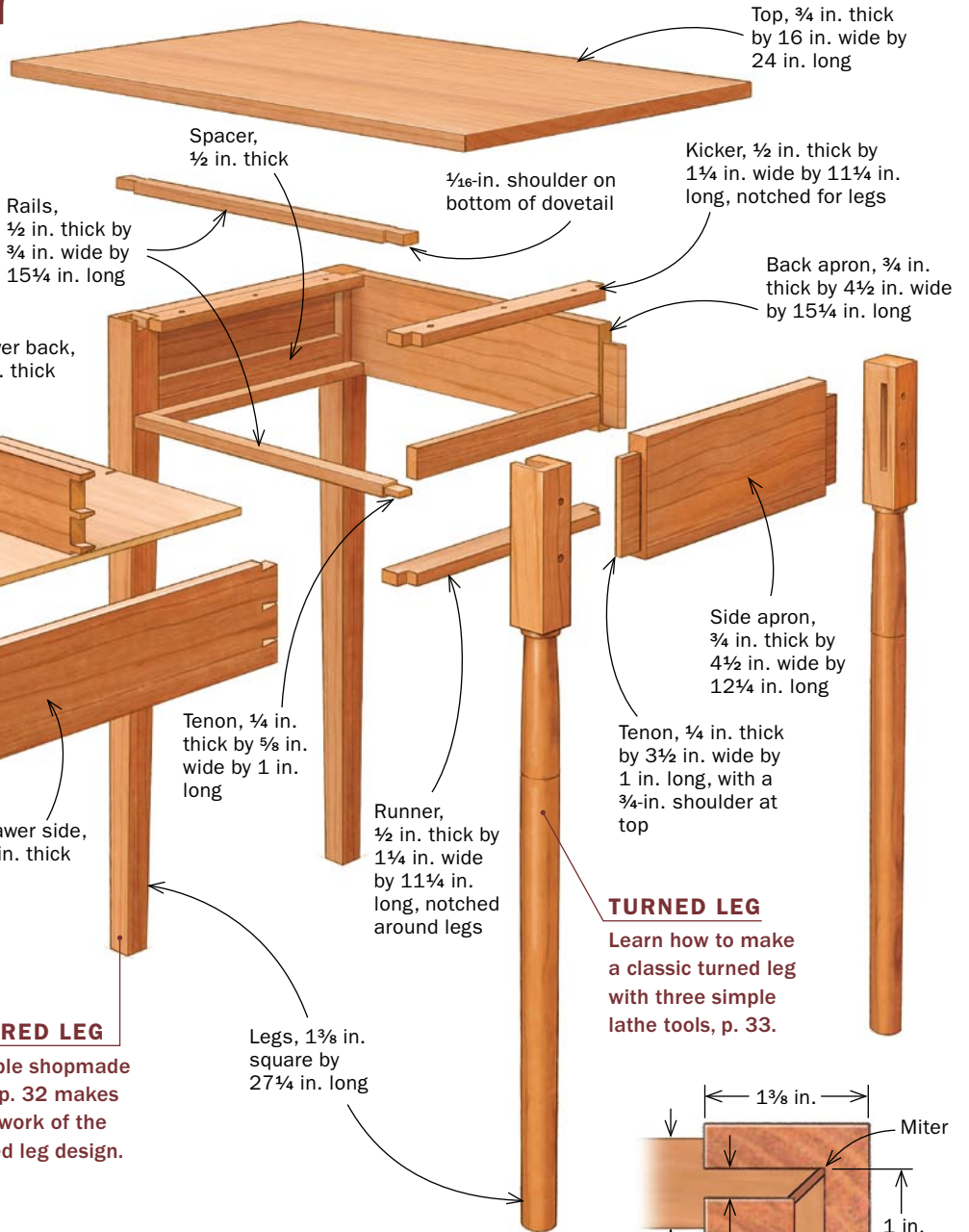

2 options for legs

When building tables, it's logical to start with the legs because they tie all the other parts together. Use a tapering jig on the tablesaw to taper the two inside faces, or turn the round legs on the lathe.

Use a leg to lay out the jig. Then bandsaw the leg cutout on the top piece.

A JIG MAKES TAPERS EASY

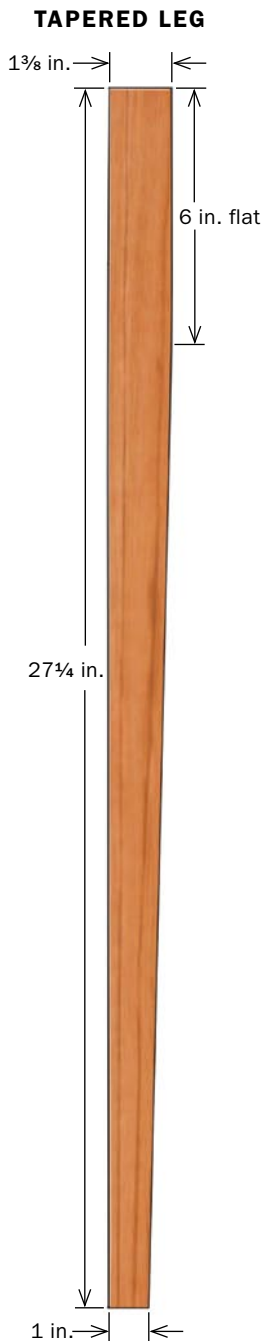
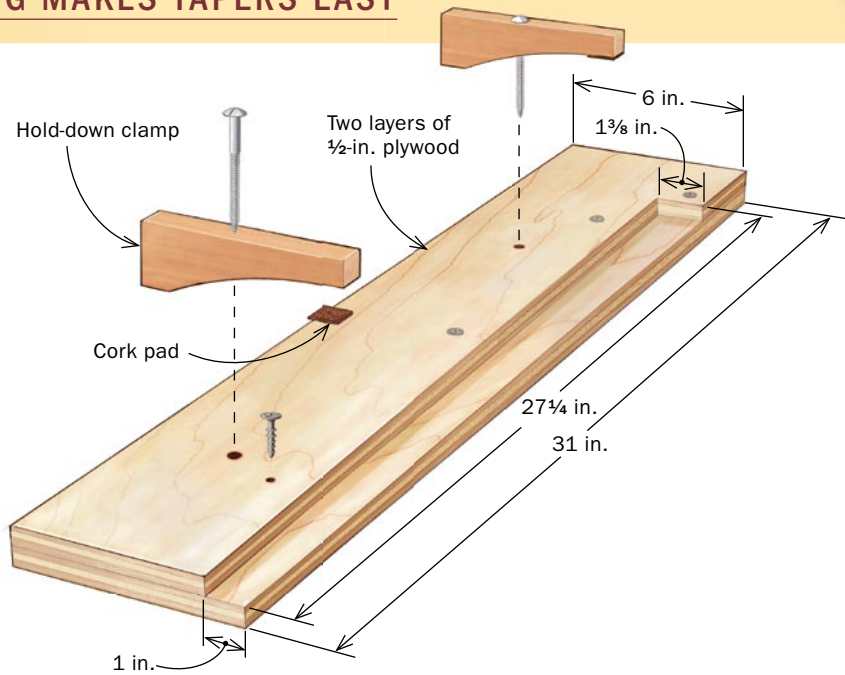

The tapering jig to create these two-sided tapered legs is simple to make. Use a piece of plywood 4 in. to 6 in. wide and 3 in. to 4 in. longer than the leg. I mark the end of the leg to see the final dimensions and use those marks to position the leg on the plywood. Set the leg on the edge of the plywood with the portion to be tapered flush with the end and overhanging the edge. Then, trace around the leg and cut the leg area away freehand on the bandsaw. Once that's done, screw that piece of plywood to a base piece and add hold-down clamps to keep the leg stock secure as you run it through the tablesaw.

After cutting the first taper, turn the leg 90° in the jig and cut the second one. The final step is cleaning up the tapers with a sander.



First taper. With the leg in the jig and the rip fence set to the width of the jig, rip the taper on the first inside face of the leg.

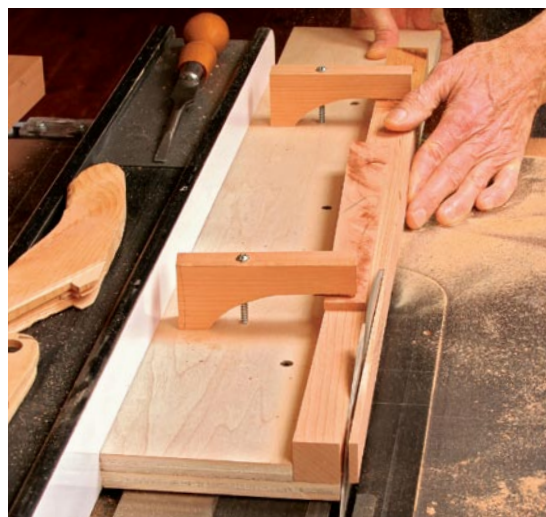

Second taper. Turn the leg blank 90° in the jig and cut the taper on the second inside face.

SIMPLE TOOLS FOR TURNING

Online Extra

For a video of Becksvoort turning this leg, go to FineWoodworking.com/extras.

Square to round. Using a ½-in. gouge, start to turn the blank round from the line down. Turn it to its widest diameter (1¼ in.).



Define the transition point. With a very sharp diamond-point scraper held on edge, carefully cut in at 90°, clearly defining the point where the square collar ends.



TURNED LEG

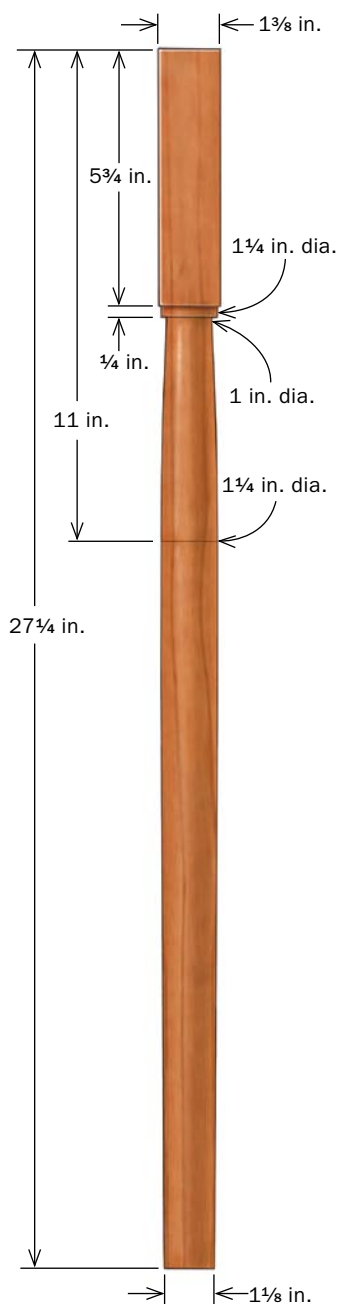

Although the turned legs aren't as easy as the tapered legs, the turning is pretty basic. There are a few points to keep in mind: the transition where the square top turns round, the ¼-in.-wide ring just under that, the maximum diameter, and the gentle taper down to the bottom of the leg.

Going from the square top portion to the round at a 90° angle is a little tricky, since a false move can knock off the corners. If you're not too secure on the lathe, you can start with 1 5/8-in.-square stock, and size it to 1 3/8 in. after turning to remove any tearout.

First, measure and mark the transition location on all four sides of the leg. Then begin turning with a ½-in. gouge as close to that point as possible. Next, with a diamond-point scraper held on edge, carefully cut in at 90°. Move the tool straight in to slice and clean up the shoulders, cutting in just deep enough to form a round. Now clean up the round ring to about 1¼ in. dia. Just under that, cut in another ¼ in. to reduce the diameter. Mark down 5 in. and cut a thin line at the maximum diameter (1¼ in.). Then use the diamond-point tool to cut to the bottom. To form the swell taper, I use a gouge and turn from below the transition ring to the max point, then taper gently to the bottom. Finish with sandpaper and 0000 steel wool. Add a light bevel at the bottom. On all the legs (tapered and turned), I break square corners with P220-grit sandpaper.

Create a ¼-in. ring. Still using the diamond-point scraper, establish the bottom part of the ring and cut in another ¼ in. to bring the diameter down a bit more.



Establish the maximum diameter. Becksvoort uses a mortising chisel on edge to cut a thin line where the turned leg is at its widest point.



Form the swell. With a ½-in. gouge, start from below the transition ring and turn a gentle curve up to the thin line, and then taper down gently to the bottom of the leg.



Fast mortises

The basic mortise-and-tenon construction makes this an easy project to tackle. A drill press and chisel are all that's needed to create the mortises.



Waste away material on the drill press. After the mortise locations are marked on the leg, use a fence clamped to the table to align a brad-point bit as you clear most of the mortise.

the side and back aprons and drawer rails to the legs. I start with the mortises for the back and side aprons and the rail below the drawer. Then I cut the tenons on all of those pieces. The rail above the drawer is dovetailed into the top of the leg, and I tackle that after the mortises and tenons.

Mortise the legs—I have a dedicated slot-mortiser for this job, but a drill press and mortising chisel also will work. After you lay out the locations for the mortises, waste away the majority of the material on the drill press with a brad-point bit. Then you can use chisels to clean up the edges and ends.

Tenon the aprons and lower front stretcher—I cut the apron tenons on the tablesaw using a dado blade (see “Tenon Shootout” on p. 42 for more on this method). There are three different blade-height settings, one for each cheek and one for the top and bottom edges. By the way, the first cheek-cut height isn't critical; it's the second one that sets the final thickness and fit of the tenons. Also, on legs this small I try to maximize the length of the tenons, so I do end up mitering them.

I cut the lower front-rail tenons the same way as I cut the apron tenons. Then I use the shoulder-to-shoulder measurement of that piece to mark out the dovetail shoulders for the upper rail.

Dovetail the upper front rail to the legs—Once I have dry-fitted the three aprons and the bottom rail, I lay out the dovetails on both ends of the top rail, cut them with a handsaw, and refine them with a chisel. On the tablesaw, I skim a small rabbet on the underside of the dovetail, which creates a shoulder and helps locate the dovetail on the leg. Once that's done, transfer the dovetails to the tops of the front legs, using a knife. A small router with a 1/8-in. or 1/4-in. bit takes out most of the waste material. Use a chisel to clean the corners.



Clean up the mortises with chisels. Mark the depth of the mortise on a mortising chisel. Starting at the ends of the mortise (left), tap the mortising chisel squarely in place. Finish by cleaning up the mortise walls with a regular bench chisel (above). For two ways to cut the tenons, see “Tenon Shootout” on p. 42.

Dovetailed rail adds strength

A quick dovetail locks the top rail in place and adds extra sturdiness to the whole base. Dovetail the rail and then cut the mating slots in the legs.

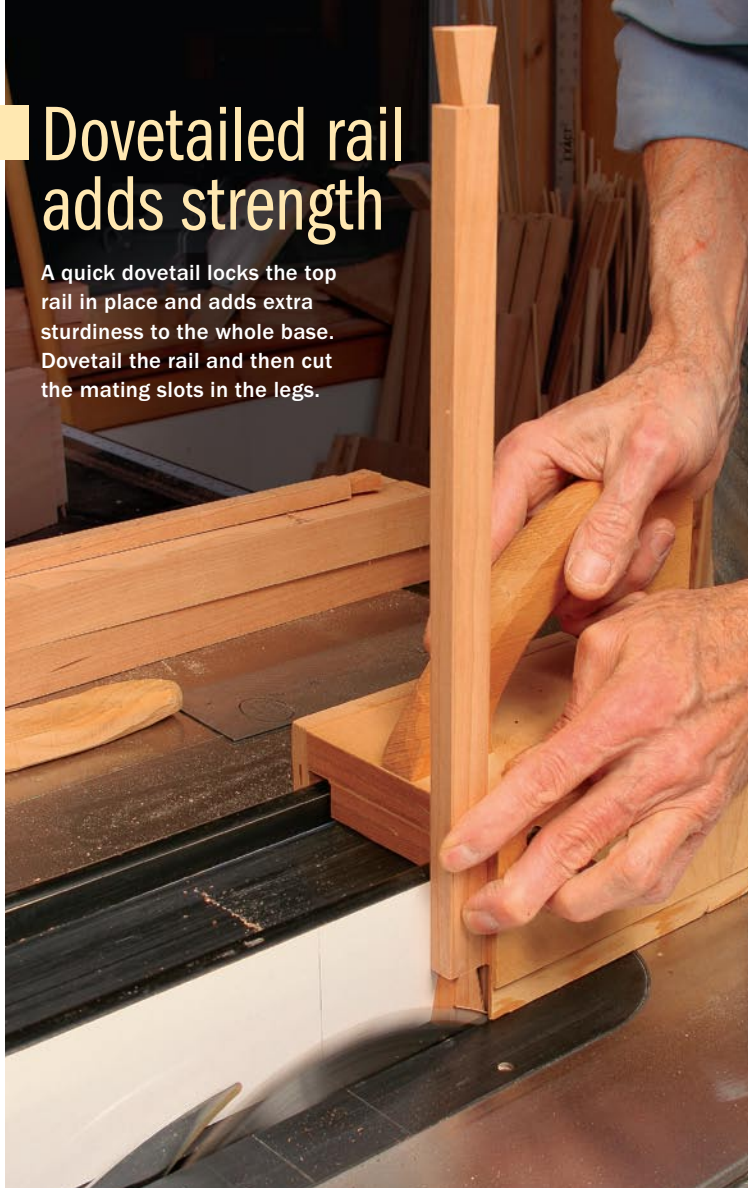

Cut a rabbet on the underside of the dovetails. Use a tenoning jig. The shallow lip ($\frac{1}{16}$ in.) helps when you are marking the dovetail's position on the legs.

Glue up the bases and add runners, kickers, and spacers

Before adding the runners and kickers, sand the legs, aprons, and rails to P320-grit and glue the bases together. Begin by gluing the front legs to the rails and the back legs to the back apron in two separate assemblies. Once they are dry, add the two side aprons as a final assembly. And once that is dry, you can glue in the runners and kickers.

The drawer runners and kickers (a pair on each side of the drawer) are the same size and shape, simply a strip of wood notched to fit between the front and back legs. The runners sit below the drawer sides and provide the track that the drawer runs on while it moves in and out of the side table. A kicker is a strip of wood that is placed above each drawer side to keep the drawer from tipping down as it is opened and closed. In addition, I use the kicker to screw the top in place. Also, because the sides are inset from the legs, I glue in a spacer just above the runner. This spacer keeps the drawer from tilting left or right.

There is no joinery involved in adding the runners and kickers; they are simply cut to fit the interior, then glued and



Transfer the layout to the legs.

Dry-fit the lower rail to the legs, and position the upper rail across the top of the legs to transfer the dovetail profile (above). Use a small router to cut close to the line (left) and a chisel to finish the job.



Fit the upper rail.

A final dry-fit of the rails to the front legs ensures an accurate fit and a stress-free glue-up. These parts will be the first step of the gluing process.



Assemble in stages

Start with the front and back, gluing the back apron to the back legs and the front stretchers to the front legs. Then join the two assemblies, and add the internal pieces that form the drawer pocket.



Complete the base. After the front and back of the base are dry, add the side aprons.

clamped in place, flush with the top and bottom of the aprons and rails. Trim the spacers perfectly flush with the inside faces of the legs.

Hand-cut dovetails in the drawers

The drawer fronts are cut to fit the openings. I make my fronts $\frac{3}{4}$ in. thick, the back $\frac{5}{8}$ in. thick, and the sides $\frac{1}{2}$ in. thick. I make the back a little thicker than the sides for three reasons: First, thinner sides make the drawer appear more graceful, and you'll seldom pull it all the way out to see the thickness of the back. Second, the added thickness gives a bit more glue surface to the dovetails, resulting in stronger joints on all four corners. Finally, it allows a solid bottom (not plywood) to expand and contract while remaining hidden under the back.

I cut half-blind dovetails in the front and through-dovetails in the back, cutting the tails first. I make the drawer bottoms from resawn, book-matched stock and secure them with a screw and slot in the back to allow for seasonal movement.



No joinery for runners, kickers, and spacers. The runners and kickers are simply glued and clamped into place (above), flush with the top and bottom of the aprons and rails. Plane the spacers perfectly flush with the inside faces of the legs before gluing them on (below).



I turn the mushroom-shaped knobs on the lathe (see "Authentic Shaker Knobs," *FWW* #196).

Screw the top in place

Last, I edge-glide the $\frac{3}{4}$ -in.-thick top, cut it to size, sand it, and use the tablesaw to add a slight bevel to the underside. With the top facedown, I center the base (1½ in. front and back, 4 in. on the sides) and drill three countersunk holes through each of the drawer kickers (one in the center, one at either end) to screw the base to the top. I made the end holes oval-shaped to allow for wood movement.

I give the tables three coats of an oil finish. The first coat is straight Danish oil and the next two coats are a ratio of two parts Tried & True Varnish oil and one part spar varnish. I use only wax on the drawer runners, spacers, kickers, and drawer sides and bottom, to help them run more smoothly. □

Christian Becksvoort is a contributing editor.

Dovetailed drawer adds function, beauty

Use these handy tricks to cut flawless dovetails by hand.

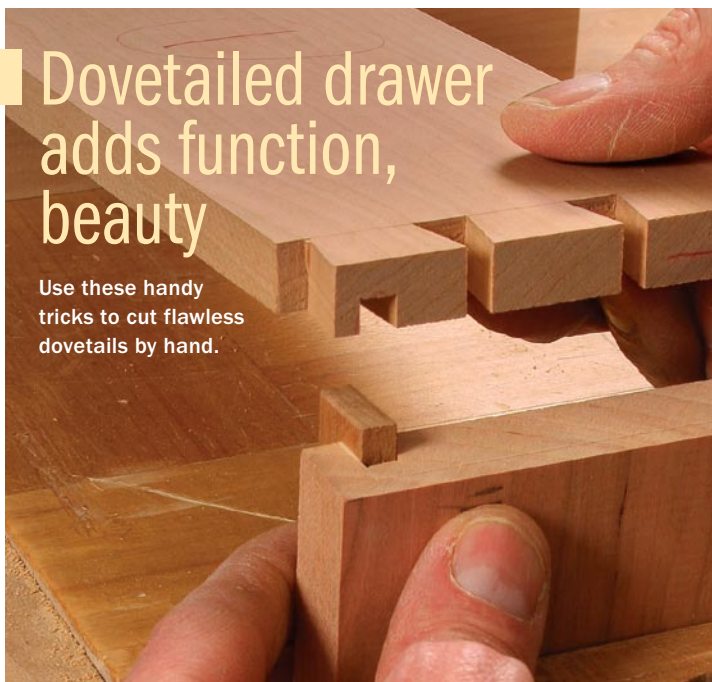

Transfer trick. Becksvort runs the groove for the drawer bottom on the tablesaw, and then uses the groove (and a small scrap) to align the parts when transferring the tails to the pin board.



Keep it level. Secure the pin board in a vise and use a spacer block to keep the tail board level on the pin board for layout.



Solid drawer bottom made easy. Cut the bottom of the drawer back to line up with the drawer groove, so the bottom can slide into place. A single screw secures the solid bottom to the back, with a slot to allow seasonal movement.



Shakers used an easy oil finish. After all the construction is finished, Becksvort uses an oil finish inside and out, but uses only wax on the interior drawer parts.

Jeff Miller Workshop
Side Table

QTY	DESCRIPTION	SIZE (T x W x L)
1	Top	3/4" x 16" x 24"
4	Leg	1 3/8" x 1 3/8" x 27 1/4"
1	Back Apron	3/4" x 4 1/2" x 15 1/4"
2	Side Apron	3/4" x 4 1/2" x 12 1/4"
2	Rail	1/2" x 3/4" x 15 1/4"
2	Kicker	1/2" x 1 1/4" x 11 1/4"
2	Runner	1/2" x 1 1/4" x 11 1/4"
2	Spacer	1/2" x 1 1/4" x 10 1/4"
1	Drawer Front	3/4" x 3 1/2" x 13 1/4"
2	Drawer Side	1/2" x 3 1/2" x 11 3/4"
1	Drawer Back	5/8" x 2 15/16" x 13 1/4"
1	Drawer Bottom	1/4" x 11 1/2" x 12 3/4"

***GET 12 BOARD FEET OF 4/4 MATERIAL**

**Glue up 2pcs of 4/4 material to make legs or get 8/4 material

- 1 Hand Pull
- 6 Flat Head Screw #8 x 1 1/4"
- 1 Round Head Screw #6 x 3/4"
- 1 Flat Washer #6
- 1 Dowel 1/4" dia x 12" (for pegging joints)

Tool List

Chisels 1/4" to 1"

no. 4 smoothing plane

block plane

dovetail saw

handsaw

marking gauge

combination square;

cordless drill and bits

small ruler

tape measure

pencils & pens

small clamps

WorkMate or similar bench, plus sandbags, bricks, etc. to hold the bench in place.